

Model 261GS for gauge pressure Model 261AS for absolute pressure

2600T series pressure transmitters

Engineered solutions for all applications



Standard overload resistance

Base accuracy

— $\pm 0.1\%$

Span limits

- 0.3 ... 60,000 kPa; 1.2 in H₂O up to 8,700 psi
- 0.3 ... 3,000 kPa abs.; 2.25 mmHg up to 435 psia

Proven sensor technology together with state-of-the-art digital technology

- Large turn down ratio of up to 20:1

Stainless steel housing

- Optimized for use in extreme conditions
- Extremely sturdy design

Flexible configuration options

- Local configuration via setup button for upper and lower range values
- Local configuration via keys on LCD indicator
- Via handheld terminal or PC user interface

Full compliance with Pressure Equipment Directive (PED) category III

Model 261GS for gauge pressure

Model 261AS for absolute pressure

Functional Specifications

Measuring range limits and span limits

Sensor code	Measuring range upper limit (URL)	Measuring range lower limit (LRL) Model 261GS	Minimum measuring span	
			Model 261GS Gauge pressure	Model 261AS Absolute pressure
C	6 kPa 60 mbar 24 inH ₂ O	-6 kPa -60 mbar 24 inH ₂ O	0,3 kPa 3 mbar 1,2 inH ₂ O	0,3 kPa 3 mbar 2,25 mm Hg
F	40 kPa 400 mbar 160 inH ₂ O	-40 kPa -400 mbar -160 inH ₂ O	2 kPa 20 mbar 8 inH ₂ O	2 kPa 20 mbar 15 mm Hg
L	250 kPa 2500 mbar 1000 inH ₂ O	0 abs	12,5 kPa 125 mbar 50 inH ₂ O	12,5 kPa 125 mbar 93,8 mm Hg
D	1000 kPa 10 bar 145 psi	0 abs	50 kPa 500 mbar 7,25 psi	50 kPa 500 mbar 375 mm Hg
U	3000 kPa 30 bar 435 psi	0 abs	150 kPa 1,5 bar 21,7 psi	150 kPa 1,5 bar 21,7 psi
R	10000 kPa 100 bar 1450 psi	0 abs	500 kPa 5 bar 72,5 psi	500 kPa 5 bar 72,5 psi
V	60000 kPa 600 bar 8700 psi	0 abs	3000 kPa 30 bar 435 psi	-

IMPORTANT (NOTE)

The measuring range lower limit (LRL) for model 261AS is absolute 0 for all measuring ranges.

Span limits

Maximum span = measuring range upper limit (URL)

To optimize performance characteristics, it is recommended that you select the transmitter sensor code with the lowest turn down ratio.

TURNDOWN = Upper range limit / set span

Zero suppression and elevation

The zero position and span can be set to any value within the measuring range limits listed in the table if:

- Set span ≥ minimum span

Damping

Configurable time constant between 0 and 60 s.

This is in addition to the sensor response time, and can be adjusted via the optional LCD indicator, handheld terminal, or PC user interface.

Warm-up time

Ready for operation as per specifications in less than 10 s with minimum damping.

Insulation resistance

>100 MΩ at 500 V DC (between terminals and ground).

Operative limits

Pressure limits

Overpressure limits

No damage will occur during transmitter operation, if they are used within the specifications and subject to the following limits:

Sensor code	Overpressure limits, 0 abs to:
C, F	1 MPa, 10 bar, 145 psi
L	0.5 MPa, 5 bar, 72.5 psi
D	2 MPa, 20 bar, 290 psi
U	6 MPa, 60 bar, 870 psi
R	20 MPa, 200 bar, 2,900 psi
V	90 MPa, 900 bar, 13,050 psi
Perfluoroelastomer gasket T ≥ -15 °C (5 °F)	0.6 MPa abs, 6 bar abs, 87 psia
Perfluoroelastomer gasket T ≥ -25 °C (-13 °F)	0.18 MPa abs, 1.8 bar abs, 26 psia

Test pressure

When carrying out the transmitter pressure test, it is essential to observe the overpressure limits!

Temperature limits °C (°F)

Environment

Model 261GS, 261AS	Ambient temperature limits
Operating temperature range	-40 ... 85 °C (-40 ... 185 °F)
White oil filling	-6 ... 85 °C (21 ... 185 °F)
LCD display	-20 ... 70 °C (-4 ... 158 °F)
Viton seal	-20 ... 85 °C (-4 ... 185 °F)
Perfluoroelastomer gasket (see also "Pressure limits")	-25 or -15 ... 80 °C (-13 or 5 ... 176 °F)

IMPORTANT (NOTE)

For applications in potentially explosive atmospheres, the temperature range specified on the relevant certificate/approval must be observed.

Process

Model 261GS, 261AS	Process temperature limits
Process temperature range	-50 ... 120 °C (-58 ... 248 °F)
White oil filling	-6 ... 120 °C (21 ... 248 °F) ¹
Viton seal	-20 ... 120 °C (-4 ... 248 °F)
Perfluoroelastomer gasket (see also "Pressure limits")	-25 or -15 ... 80 °C (-13 or 5 ... 176 °F)

¹ ≤ 85 °C (185 °F) for operating pressures below the atmospheric pressure

Storage

Model 261GS, 261AS	Storage temperature range
Storage temperature range	-50 ... 85 °C (-58 ... 185 °F)
LCD display	-40 ... 85 °C (-40 ... 185 °F)
White oil filling	-6 ... 85 °C (21 ... 185 °F)

Model 261GS, 261AS	Humidity during storage
Relative humidity	Up to 75 %

Environmental limits

Electromagnetic compatibility (EMC)

The devices conform to the requirements and tests for EMC Directive 2004/108/EC, as well as EN 61000-6-3 concerning emitted interference and EN 61000-6-1, EN 61000-6-2 concerning interference immunity. The devices fulfill NAMUR recommendations.

Low Voltage Directive

The devices meet the requirements of Directive 2006/95/EC.

Pressure Equipment Directive (PED)

The devices meet the requirements of Directive 97/23/EC, Category III, module H.

Humidity

Relative humidity: Up to 100 %
Condensation, icing: Permissible

Vibration resistance

Acceleration up to 2 g at frequencies of up to 1,000 Hz (according to IEC 60068-2-6).

Shock resistance

Acceleration: 50 g
Duration: 11 ms
(according to 60068-2-27)

Humid and dusty atmospheres (degree of protection)

The transmitter is dust and sand-tight, and is protected against immersion effects as defined by the following standards:

- IEC EN60529 (1989) with IP 67
(with IP 68, IP 69K on request)
- NEMA 4X
- JIS C0920

IP65 degree of protection with plug connection

Model 261GS for gauge pressure Model 261AS for absolute pressure

Hazardous atmospheres

ATEX transmitter with type of protection "intrinsic safety Ex ia/ib" in accordance with Directive 94/9/EC

Transmitter with 4 ... 20 mA output signal and HART communication	
Certificate no.	PTB 05 ATEX 2032
Labeling	II 1/2 G Ex ia IIC T4 ... T6 II 2 G Ex ib IIC T4 ... T6

Permissible ambient temperature range according to temperature class:

Ambient temperature	Temperature class
-40 ... 85 °C (-40 ... 185 °F)	T1 ... T4
-40 ... 71 °C (-40 ... 159 °F)	T5
-40 ... 56 °C (-40 ... 132 °F)	T6

or

Labeling	II 1/2 D IP65 T95 °C Ex ia D II 2 D IP65 T95 °C Ex ib D
----------	--

Permissible ambient temperature range:
-40 ... 85 °C (-40 ... 185 °F)

Supply and signal circuit with "Intrinsically safe Ex ia/ib IIB/IIC" type of protection", with the following maximum values

	$U_i = 30 \text{ V}$
	$I_i = 130 \text{ mA}$
	$P_i = 0.8 \text{ W}$
Effective internal capacitance	$C_i = 10 \text{ nF}$
Effective internal inductance	$L_i = 0.5 \text{ mH}$

IECEx transmitter with the following types of protection: "intrinsic safety ia", "non sparking nA" and "dust ignition protection by enclosure tb"

Transmitter with 4 ... 20 mA output signal and HART communication	
Certificate no.	IECEx ZLM 10.0002
Labeling	Ex ia IIC T6 bzw. T4 Ga/Gb Ex ia IIIC T66°C bzw. T95°C Da/Db Ex nA IIC T6 bzw. T4 Gc Ex tb IIIC T66°C bzw. T95°C Db

Maximum permissible ambient temperature range according to temperature class

Ambient temperature	Temperature class	Surface temperature
-40 ... 85 °C (-40 ... 185 °F)	T4	95 °C (203 °F)
-40 ... 56 °C (-40 ... 133 °F)	T6	66 °C (151 °F)

Electrical data according to designation Ex ia IIC T6 or T4 Ga/Gb and Ex ia IIIC T66°C or T95°C IP6X Da/Db

Supply and signal circuit with "intrinsic safety" Ex ia or Ex ib type of protection, for connection to power supply units with the following maximum values (terminal signal ±)

	$U_i = 30 \text{ V}$
	$I_i = 130 \text{ mA}$
	$P_i = 0.8 \text{ W}$
Effective internal capacitance	$C_i = 10 \text{ nF}$
Effective internal inductance	$L_i = 0.5 \text{ mH}$

If the transmitter is being integrated into a partition between equipment protection level Ga or Da and a lower protection level, the transmitter must be supplied with power by an Ex ia intrinsically safe circuit.

Electrical data according to designation Ex nA IIC T6 or T4 Gc and Ex tb IIIC T66°C or T95°C IP6X Db

	$I_N \leq 22,5 \text{ mA}$
	$U_N \leq 45 \text{ V}$

Factory Mutual (FM)

Transmitter with 4 ... 20 mA output signal and HART communication	
Intrinsic Safety	Class I; II and III; Division 1; Groups A, B, C, D; E, F, G Class I; Zone 0; AEx ia Group IIC T6; T4
Non-incendive	Class I, II, III, Division 2; Groups A, B, C, D, F, G
Degree of protection	NEMA type 4X (indoor and outdoor installation)

Canadian Standards Association (CSA)

Transmitter with 4 ... 20 mA output signal and HART communication	
Intrinsic Safety	Class I; II and III; Division 1; Groups A, B, C, D; E, F, G Class I; Zone 0; Group IIC T6; T4
Non-incendive	Class I, II, III; Division 2; Groups A, B, C, D; F, G
Degree of protection	NEMA type 4X (indoor and outdoor installation)

Permissible ambient temperature range according to temperature class:

	U _i max. = 30 V; I _i max = 130 mA; P _i = 0,8 W; C _i = 10 nF; L _i = 0,5 μH		
Ex ia II CT1 ... T6	T6	T5	T1 ... T4
	-40 ... 56 °C	-40 ... 71 °C	-40 ... 85 °C

Intrinsic safety	Gas and dust, order code X4
Degree of protection	Ex ia II CT1~T6; DIP A20 T _A 95 °C

NEPSI (China)

Transmitter with 4 ... 20 mA output signal and HART communication	
Intrinsic Safety	(Gas, order code X3)
Designation	Ex ia II CT1~CT6

Permissible ambient temperature range according to temperature class:

	U _i max. = 30 V; I _i max = 130 mA; P _i = 0,8 W; C _i = 10 nF; L _i = 0,5 μH		
Ex ia II CT1 ... T6	T6	T5	T1 ... T4
	-40 ... 56 °C	-40 ... 71 °C	-40 ... 85 °C
DIP A20 T _A 95 °C	-40 ... 85 °C		

Model 261GS for gauge pressure Model 261AS for absolute pressure

Electrical Characteristics and Options

HART digital communication and 4 to 20 mA output

Power supply

The transmitter operates from 11 ... 42 V DC with no load and is protected against reversed polarity (additional loads enable operation above 42 V DC).

During use in Ex ia zones and in other intrinsically safe applications, the power supply must not exceed 30 V DC.

Ripple

Maximum permissible supply voltage ripple during communication: Complies with HART FSK “Physical Layer” specification rev. 8.1.

Load limitations

Total loop resistance at 4 ... 20 mA and HART:

$$R(k\Omega) = \frac{\text{Voltage supply} - \text{Minimum operating voltage (VDC)}}{23.6 \text{ mA}}$$

A minimum resistance of 250 Ω is required for HART communication.

LCD display (optional)

Digital, graphic LCD display for customized visualization of:

- Gauge pressure/absolute pressure
 - Output current in mA or %, or
 - HART output (freely assigned start/end values and unit)
- Diagnostic messages, alarms, errors, and measuring range upper limit violations are also displayed.

In addition, the LCD display can be used to configure and parameterize the transmitter using 4 buttons.

Output signal

Two-wire, 4 ... 20 mA output.

HART® communication provides digital process variables (% , mA or engineering units) superimposed on the 4 ... 20 mA signal (protocol according to Bell 202 FSK standard).

Output current limits (according to NAMUR standard)

Overload condition

- Lower limit: 3.8 mA (configurable up to 3.5 mA)
- Upper limit: 20.5 mA (configurable up to 23.6 mA)

Alarm current

- Minimum alarm current: 3.5 mA (configurable from 3.5 ... 4 mA)
- Maximum alarm current: 21 mA (configurable from 20 ... 23.6 mA)

Default setting: High Alarm Current

SIL: Functional safety (optional)

According to IEC 61508/61511

Device with certificate of conformity for use in safety-related applications, up to and including SIL 2.

Performance specifications

Reference conditions according to IEC 60770

- Ambient temperature TU = constant in the range 18 ... 30 °C (64 ... 86 °F)
- Relative humidity = constant in the range 30 ... 80 %
- Ambient pressure PU = constant in the range 950 ... 1,060 mbar.
- Measuring span based on zero position
- Transmitter with ceramic or Hastelloy separation diaphragm
- Filling fluid: Silicone oil
- Supply voltage: 24 V DC
- Load with HART: 250 Ω
- Transmitter not grounded
- Characteristic setting: linear, 4 ... 20 mA.

Unless otherwise stated, errors are specified as a % of the measuring span value.

The accuracy of the measurement in relation to the upper range limit (URL) is affected by the turndown (TD); i.e., the ratio of the upper range limit (URL) to the set span (URL/span). FOR OPTIMUM MEASURING ACCURACY, IT IS RECOMMENDED THAT YOU SELECT THE SENSOR CODE WHICH WILL PROVIDE THE LOWEST TD VALUE.

Dynamic response (according to IEC 61298-1)

Reaction time	100 ms
Time constant (63.2 % of total step response)	150 ms

Measuring error for setting cut-off point

Turndown	Measuring error
1:1 ... 10:1	±0.1 %
>10:1	± (0.1 + 0.005 x TD - 0.05) %

Ambient temperature

Thermal change in ambient temperature as regards the zero signal and span (turndown up to 6:1), in relation to the set span

Temperature range	Maximum effect on zero signal and span
-10 ... 60 °C (14 ... 140 °F)	All measuring ranges ± (0.2 % x TD + 0.2 %)
-40 ... -10 °C (-40 ... 14 °F)	All measuring ranges
60 ... 85 °C (140 ... 185 °F)	±((0.1 % / 10 K) x TD + (0.1 / 10K))

Temperature coefficient (T_k)

Effect of the ambient temperature per 10 K (but limited to the maximum effect of the temperature change, see previous information). The information refers to the set measuring span.

Temperature range	Effect on zero signal and span
-10 ... 60 °C (14 ... 140 °F)	Sensor code C, F: ± (0.15 % x TD + 0.15 %)
	Sensor code L, D, U, R, V: ± (0.05 % x TD + 0.05 %)

Power supply

Within the specified limits for the voltage / load, the total influence is less than 0.001 % of the upper measuring range limit per volt.

Load

Within the specified load / voltage limits, the total influence is negligible.

Model 261GS for gauge pressure

Model 261AS for absolute pressure

Electromagnetic fields

Total influence is less than 0.3 % of measuring span from 80 ... 1,000 MHz and for field strengths up to 10 V/m when tested with unshielded conduit, with or without meter.

Mounting position

Nominal position: vertical; process connection at bottom. Mounting position deviant from the standard position influence the output due to the filling liquid. With a deviation of 90° from standard position the effect is 1.12 mbar + 0.01 mbar/10K. This effect can be compensated by carrying out zero signal adjustment and configuring the mounting angle with the LCD indicator or DTM.

Long-term stability

±(0.10 x TD) % / year

Vibration effect

±(0.10 x TD) % acc. to IEC 61298-3

Total performance

Similar to DIN 16086

In the range -10 ... 60 °C (14 ... 140 °F):

0.42% of the set span (TD 1:1)

The total performance accuracy includes the measuring error (non-linearity including hysteresis and non-reproducibility), as well as the thermal change in the ambient temperature as regards the zero signal and span.

$$E_{perf} = \sqrt{(E_{\Delta TS1} + E_{\Delta TS2})^2 + E_{lin}^2}$$

E_{perf} = Base accuracy

$E_{\Delta TS1}$ = Effect of the ambient temperature on the URL

$E_{\Delta TS2}$ = Effect of the ambient temperature on the measuring span

E_{lin} = Measuring error (for setting cut-off point)

Physical specification

(Refer to ordering information sheets for variant availability related to specific model or versions code)

Materials

Process separation diaphragms¹

Ceramic (AL₂O₃) gold-plated, Hastelloy C276,
Hastelloy C276 gold-plated,
Stainless steel (1.4435 / 316L)

Process connection¹

Stainless steel (1.4404 / 316L)

Gasket¹

(for sensor code C,F only)

Viton, perfluoroelastomer, Buna (NBR)

Sensor filling fluid

Silicone oil, inert filling (carbon fluoride), white oil (FDA)

Mounting bracket

Stainless steel

Sensor housing, electronics housing and cover

Stainless steel (1.4404 / 316L)

Filter for atmospheric ventilation

Filter housing: Plastic (standard), stainless steel (code EA, AB)

Filter material: Polyamide (PA)

Viewing window in cover (LCD display)

Polycarbonate, Makrolon 6557

O-ring cover

EPDM

Plates

Plastic data plate attached to the electronics housing

Calibration

Standard:

— 0 to upper range limit (URL)

Optional:

— To specified measuring span

Optional extras

Mounting bracket

For vertical and horizontal 60 mm (2 in.) pipes or wall mounting

LCD display

Can be rotated in 90° increments into 4 positions

Additional tag plates

Code I2: For measuring point tag (up to 30 characters) and calibration specifications (up to 30 characters: lower and upper value plus unit), attached to transmitter housing.

Code I1: For customer data (4 lines with 30 characters each), attached to transmitter housing with wire.

Cleaning stage for oxygen applications (O2)

Certificates (test, design, characteristics, material traceability)

Name plate and operating instruction language

Communication plug connectors

Process connections

1/2-14 NPT female or male thread, DIN EN 837-1 G 1/2 B or G 1/2 B (HP) for convex seal, flush diaphragm, for installation in ball valve.

¹ Transmitter parts that come into contact with fluid

Model 261GS for gauge pressure Model 261AS for absolute pressure

Electrical connections

M16 x 1.5 tap hole with cable gland (cable diameter approx. 5 ... 10 mm), directly on housing

or

M20 x 1.5 (via adapter) with cable gland (cable diameter approx. 6 ... 11 mm)

or

1/2-14 NPT (via adapter) without cable gland

or

Harting Han plug connector (with mating plug (socket outlet, for wire diameters of 0.75 ... 1 mm² and cable diameters of 5 ... 11 mm))

or

Miniature plug connector (without mating plug (socket outlet))

Terminals

HART version:

Two connections for signal/auxiliary power, for wire cross-sections from 0.5 ... 1.5 mm² (16 AWG)

Grounding (optional)

External ground terminals for wire cross-sections up to 4 mm² (12 AWG).

Mass

(without options)

— Approx. 0.7 kg (1.54 lb)

— Additional 650 G (1.5 lb)

Packing

Carton with dimensions of approx. 240 x 140 x 190 mm (9.45 x 5.51 x 7.48 in.)

Configuration

Transmitter with HART communication and 4 to 20 mA Standard configuration

Transmitters are set to the customer's specified span at the factory. The set range and measuring point number are provided on the name plate. If this data has not been specified, the transmitter will be delivered with the following configuration:

Parameter	Factory setting
4 mA	Zero position
20 mA	Measuring range upper limit (URL)
Output	Linear
Damping	0.1 s
Transmitter failure mode	21 mA
Optional LCD display	0 ... 100 %

Any or all of the configurable parameters listed above - including the upper and lower range values - can easily be changed using the optional LCD indicator, a HART handheld communicator, or a PC running the configuration software SMART VISION with DTM for 2600T.

Mounting dimensions

(not design data) - dimensions in mm (inch)
Standard version

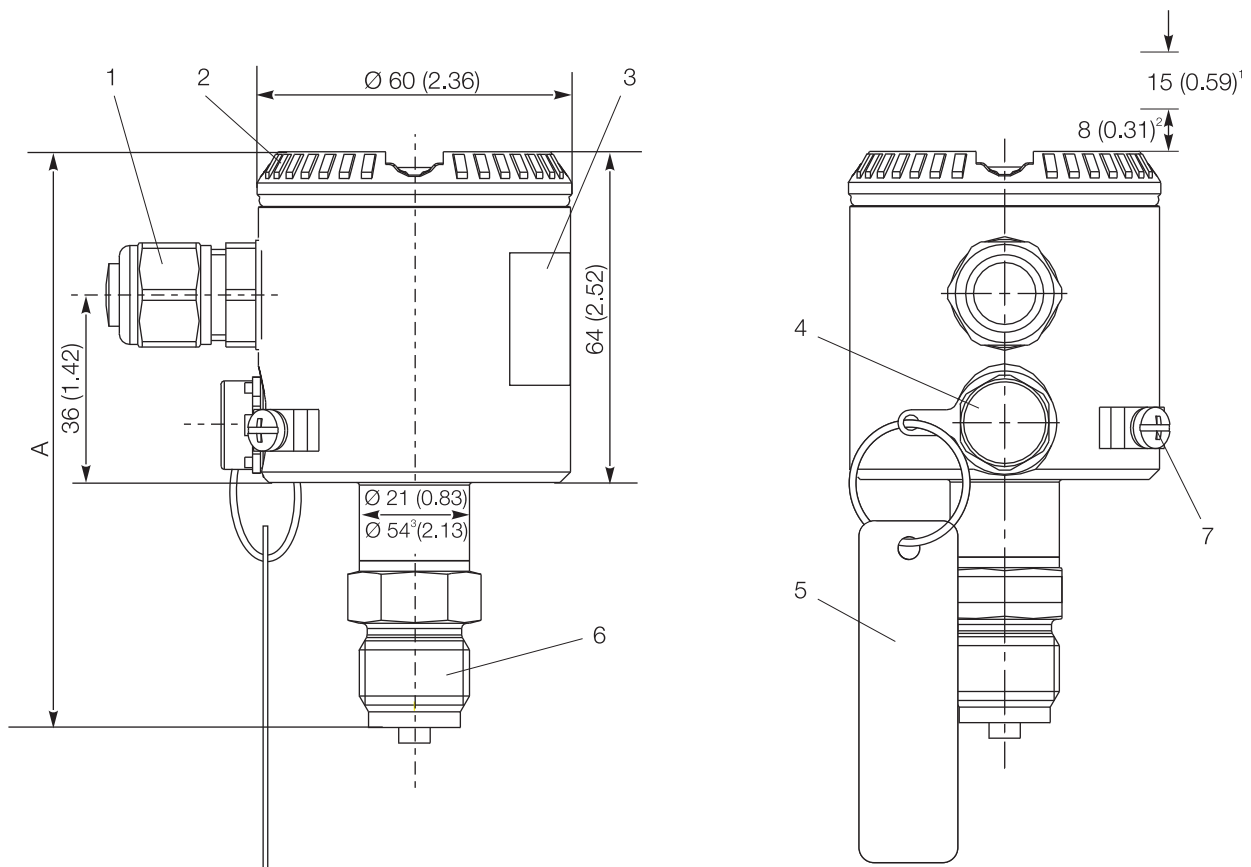

M10684

Fig. 1: Dimensions - Standard version

1 Electrical connection | **2** Housing cover | **3** Name plate | **4** Filter for atmospheric compensation | **5** Tag (optional) | **6** Process connection | **7** Grounding/equipotential bonding terminal (optional)

- 1 Space for removing the cover required
- 2 With LCD indicator
- 3 Dimensions for sensor code C, F with ceramic diaphragm material

Dimension "A" is dependent on the process connection as per the following table:

Process connection	Dimension "A" in mm (inch)
1/2-14 NPT male thread	111 (4.37)
1/2-14 NPT female thread	106 (4.17) / (110 (4.33) sensor V)
DIN EN 837-1 G 1/2 B	111 (4.37)
DIN EN 837-1 G 1/2 B (HP) for connections with convex seal	121 (4.76)

Model 261GS for gauge pressure Model 261AS for absolute pressure

Version with the options “LCD indicator” and “Harting Han plug”

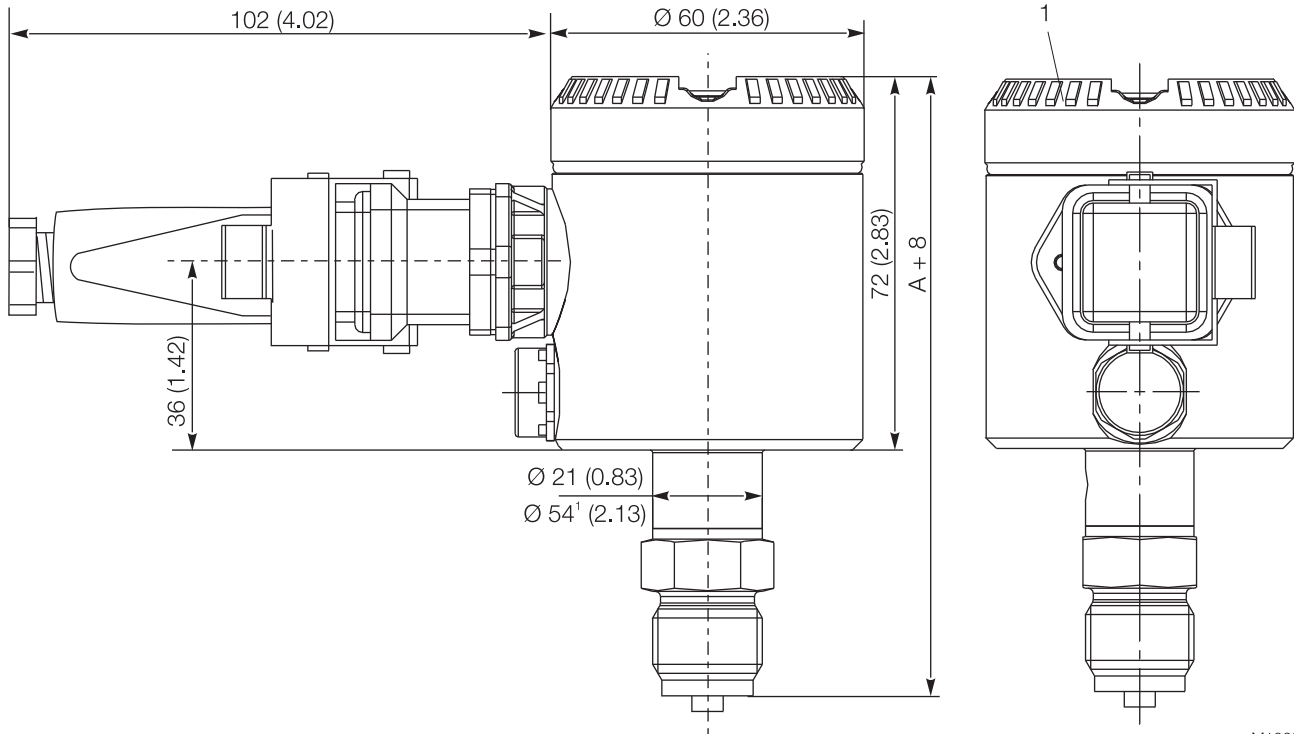

M10685

Fig. 2: Dimensions - With options
1 Housing cover for LCD indicator option

1 Dimensions for sensor code C, F with ceramic diaphragm material

Dimension "A" is dependent on the process connection as per the following table:

Process connection	Dimension "A" in mm (inch)
1/2-14 NPT male thread	111 (4.37)
1/2-14 NPT female thread	106 (4.17) / (110 (4.33) sensor V)
DIN EN 837-1 G 1/2 B	111 (4.37)
DIN EN 837-1 G 1/2 B (HP) for connections with convex seal	121 (4.76)

Transmitter with flush diaphragm

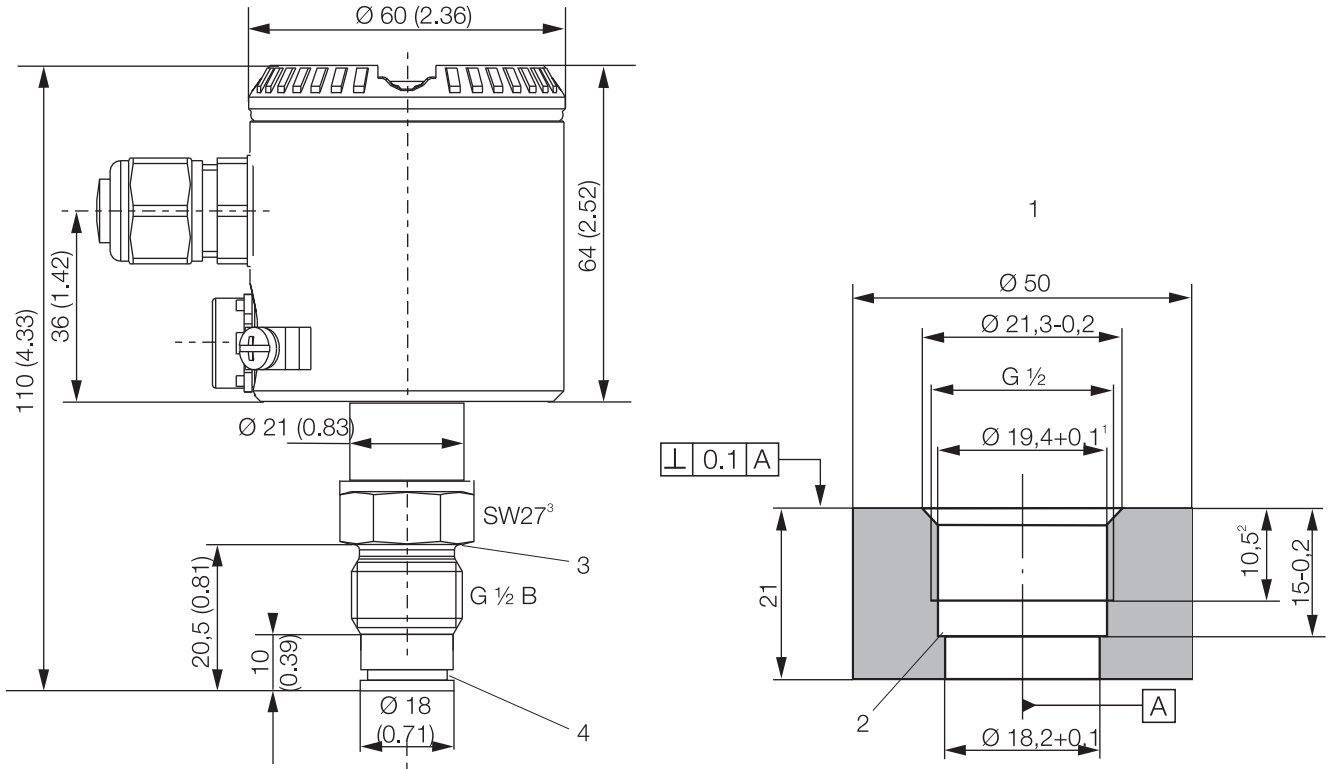

M10686

Fig. 3: Dimensions - With flush diaphragm

- 1** Welded connections / tapped hole for flush diaphragm, part no. 284903 | **2** No burrs |
- 3** Groove for gasket DIN 3869 - 21 18.5 x 23.9 x 1.5 | **4** Groove for O-ring 15 x 2

- 1 Bevel after cutting threads
- 2 Minimum dimension
- 3 Wrench size 27

Model 261GS for gauge pressure
 Model 261AS for absolute pressure

Version with ball valve connection

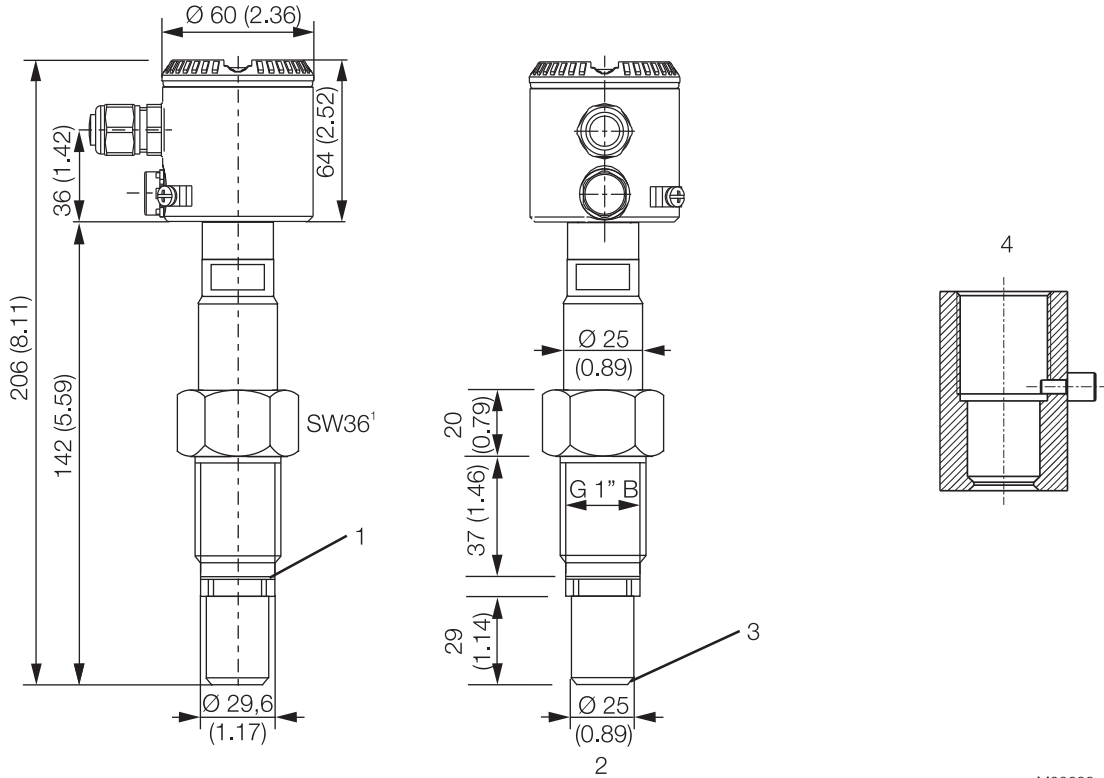
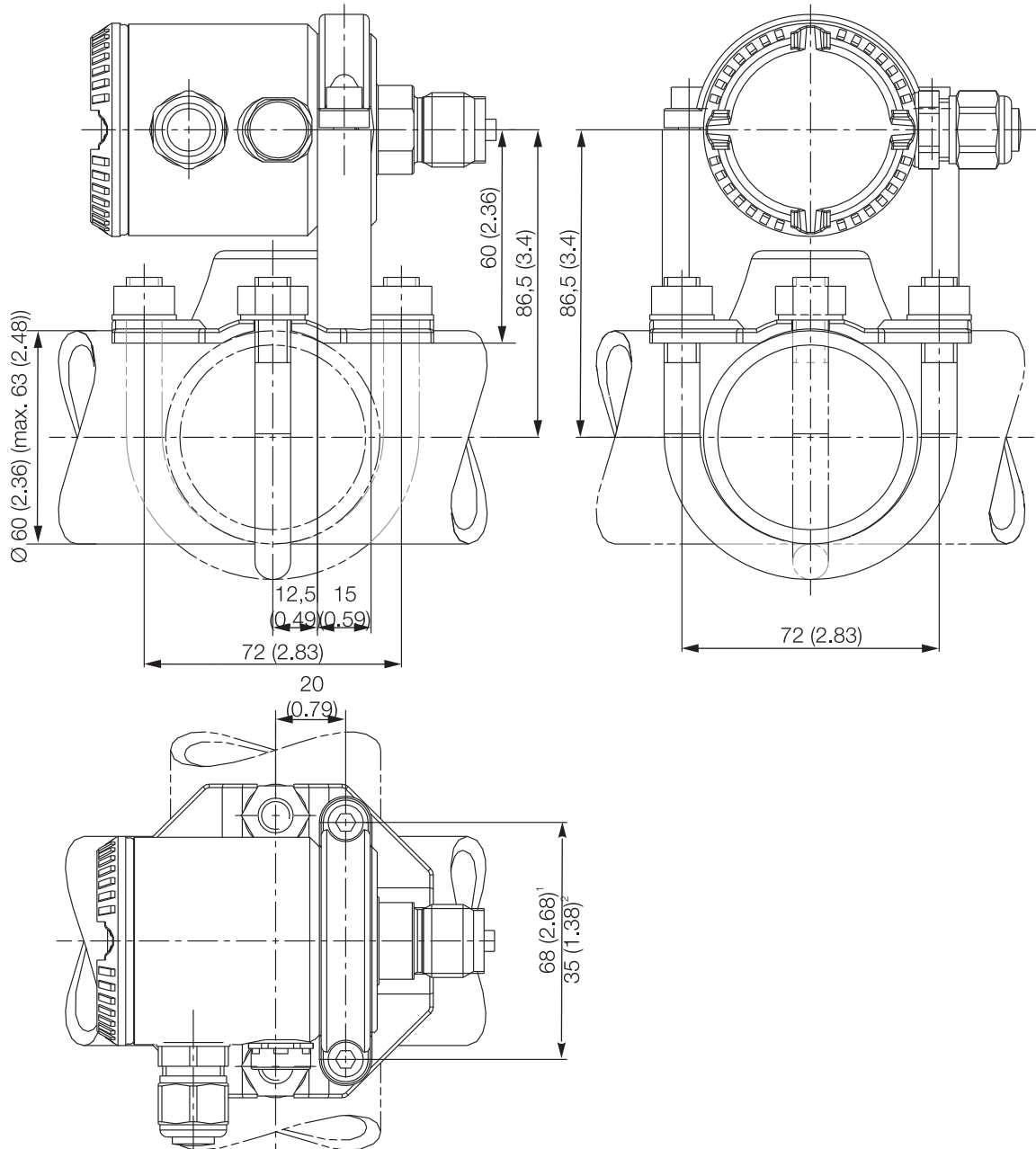

Fig. 4: Dimensions - With ball valve connection
 1 Shim | 2 Diaphragm diameter: ~ 20 mm (0.79 inch) | 3 metal / metal conical seal, diaphragm is process-bonded |
 4 Weld-in sleeve G 1", part no.: 789516

1 Wrench size 36

M00698

Mounting with angle bracket (optional)



M10688

Fig. 5: Dimensions - Pipe / wall mounting

- 1 Dimensions for sensor code C, F with ceramic diaphragm material
- 2 Sensor code C, F, L, D, U, 1, R, V with metal diaphragms

IMPORTANT (NOTE)

The bracket for wall or pipe mounting has four holes with a \varnothing of 10.5 mm. The holes are arranged in a square and spaced 72 mm away from one another.

Model 261GS for gauge pressure Model 261AS for absolute pressure

Electrical connections

HART version

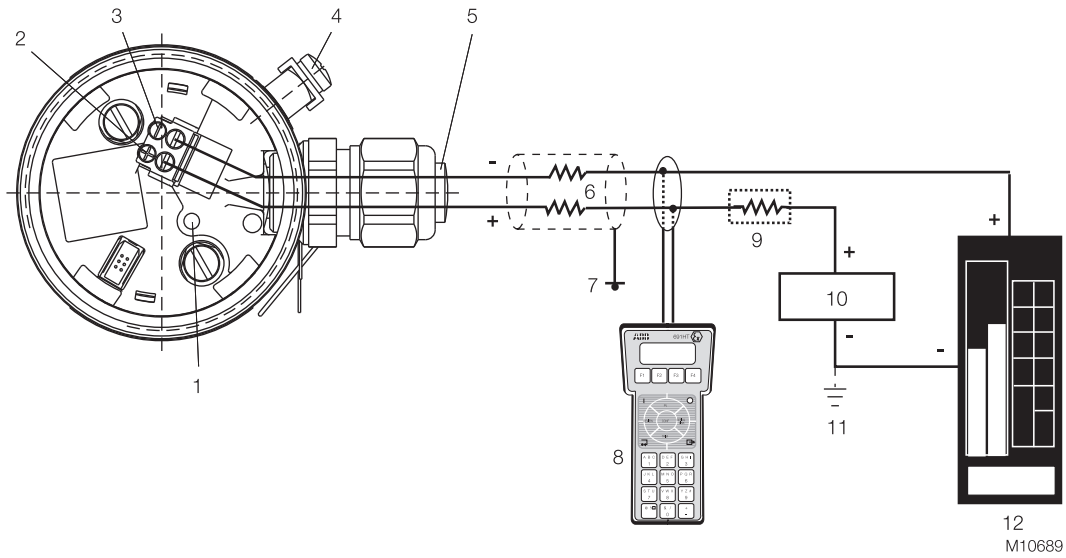

Fig. 6: Electrical connections - HART version

- 1 Pushbutton for lower/upper range values | 2 + Signal screw terminals for leads with cross-section of 0.5 ... 1.5 mm² |
- 3 - Signal screw terminals for leads with a cross-section of 0.5 ... 1.5 mm² | 4 Grounding / equipotential bonding terminal (optional) |
- 5 Cable entry | 6 Line load | 7 Grounding | 8 Handheld terminal | 9 Resistor (min. 250 Ω) |
- 10 Power supply / power supply unit | 11 Optional ground | 12 Receiver

Optional plug connectors

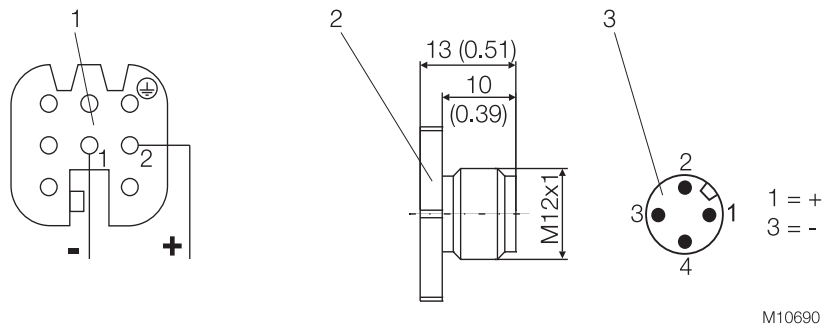

Fig. 7: Dimensions - Plug connector

- 1 Harting Han 8D (8U) socket insert for mating plug supplied (view of sockets) |
- 2 Mating plug (socket); not supplied | 3 M12 x 1 miniature plug (pins)

Ordering information

Basic ordering information 261GS Pressure Transmitters

Select one character or set of characters from each category and specify complete catalog number.

Refer to additional ordering information and specify one or more codes for each transmitter if additional options are required.

Base model – 1 st to 5 th characters				261GS	X	X	X	X	X	X
Gauge pressure transmitter, compact class, base accuracy 0.1 %										
Sensor - Span Limits – 6 th characters										continued see next page
6 kPa	60 mbar	24 in. H ₂ O (45 mm Hg)		C						
40 kPa	400 mbar	160 in. H ₂ O (300 mm Hg)		F						
250 kPa	2500 mbar	1000 in. H ₂ O (1875 mm Hg)		L						
1000 kPa	10 bar	145 psi		D						
3000 kPa	30 bar	435 psi		U						
10000 kPa	100 bar	1450 psi		R						
60000 kPa	600 bar	8700 psi		V						
Diaphragm Material / Fill Fluid – 7 th characters										
Hastelloy C-276		Silicone oil	NACE						K	
Hastelloy C-276 gold-plated		Silicone oil	NACE						G	
AISI 316L SST (1.4435)		Silicone oil	NACE						S	
Hastelloy C-276		Inert Fluid	NACE	(Note 1)					F	
Hastelloy C-276 gold-plated		Inert Fluid	NACE	(Note 1)					E	
AISI 316L SST (1.4435)		Inert Fluid	NACE	(Note 1)					A	
Hastelloy C-276		White oil (FDA)	NACE						Z	
AISI 316L SST (1.4435))		White oil (FDA)	NACE						N	
Ceramic		No filling	NACE	(Note 2)					J	
Process Connection Material / Process Connection – 8 th characters										
AISI 316L SST (1.4404)		1/2-14 NPT female	NACE							B
AISI 316L SST (1.4404)		DIN EN 837-1 G 1/2 B	NACE							P
AISI 316L SST (1.4404)		G 1/2 in. front bonded diaphragm	NACE	(Note 3)						S
AISI 316L SST (1.4404)		1/2-14 NPT male	NACE							T
AISI 316L SST (1.4404)		DIN EN 837-1 G 1/2 B (HP)	NACE	(Note 3)						U
AISI 316L SST (1.4404)		For ball valve connection	NACE	(Note 3)						V
AISI 316L SST (1.4404)		DIN 16288 M20 x 1,5	NACE							L

Model 261GS for gauge pressure

Model 261AS for absolute pressure

Basic ordering information model 261GS Pressure Transmitter		X	X	X
Gasket – 9 th characters				
Viton, NACE	(Note: 4)	5		
Perfluorelastomere, NACE (max. 0.6 MPa)	(Note: 2)	6		
Perbunan	(Note: 2)	8		
None,, NACE		N		
Electronic Housing Material / Electrical Connection – 10 th characters				
AISI 316L SST (1.4404) / M16 x 1.5 (with cable gland made of plastic)	(Note: 5)		2	
AISI 316L SST (1.4404) / 1/2-14 NPT (without cable gland)	(Note: 7)		S	
AISI 316L SST (1.4404) / M20 x 1.5 (with cable gland made of plastic)	(Note: 5)		T	
AISI 316L SST (1.4404) / Harting Han Connector	(Note: 6)		3	
AISI 316L SST (1.4404) / Miniature Connector	(Note: 6)		Z	
Output – 11 th characters				
HART digital communication and 4 ... 20 mA (Additional options not requested)	(Note: 9)			H
HART digital communication and 4 ... 20 mA (Additional options to be ordered by additional ordering code)	(Note: 8)			1

Additional ordering information for model 261GS

Add one or more 2-digit code(s) after the basic ordering information to select all required options.

	XX	XX	XX	XX	XX	XX	XX
Explosion Protection Certification							
Factory Mutual (FM) - Intrinsically Safe (Note:10)	EA						
Canadian Standard Association (CSA) - Intrinsically Safe (Note:10)	ED						
ATEX Group II Category 1/2 G - Intrinsic Safety EEx ia	EH						
ATEX Group II Category 1/2 G and 1/2 D - Intrinsic Safety EEx ia (without Cable Gland) (Note:10)	EL						
IECEX Ex ia IIC T6 + Ex nA IIC T6, Gas	ER						
IECEX Ex ia IIC T6 + Ex nA IIC T6 + Ex tb, Gas & Dust	ES						
GOST Russia - EEx ia	W1						
GOST Kazakhstan - EEx ia	W3						
GOST Ukraine - EEx ia	WA						
GOST Belarus - EEx ia	WG						
NEPSI Ex ia IIC T - T6 Gas	X3						
NEPSI Ex ia IIC T - T6 Gas & Dust	X4						
Integrated Digital Display (LCD)							
With integrated LCD display		L1					
Electronic Housing: Ground Terminal							
Housing with external grounding terminal			AA				
Electronic Housing: Cable Gland							
Cable Gland M16 x 1.5 / M20 x 1.5 and atmosphere ventilation of metal				AB			
Mounting Bracket Shape / Material							
For pipe mounting / AISI 304 SST (1.4301)					B2		
For wall mounting / AISI 304 SST (1.4301)					B4		
Applications: Oxygen							
Oil- and grease-free, for oxygen applications (O2) (Pmax = 21 MPa / 210 bar / 3045 psi, Tmax = 60 °C / 140 °F) (Note:11)						P1	
Operating Instruction Language							
German							M1
Italian							M2
Spanish							M3
French							M4
English							M5
Swedish							M7
Finnish							M8
Russian							MB
Dutch							MD

Model 261GS for gauge pressure

Model 261AS for absolute pressure

Additional ordering information for model 261GS	XX	XX	XX	XX	XX	XX	XX	XX	XX	XX
Additional Tag Plate										
Stainless steel	I1									
Certificates: 3.1 Calibration										
Inspection certificate 3.1 acc. EN 10204 of calibration		C1								
Certificates: 3.1 Cleanliness Stage										
Inspection certificate 3.1 acc. EN 10204 of cleanliness stage			C3							
Certificates: 3.1 Helium Leakage Test										
Inspection certificate 3.1 acc. EN 10204 of helium leakage test of the sensor module				C4						
Certificates: 3.1 Pressure Test										
Inspection certificate 3.1 acc. EN 10204 of pressure test					C5					
Certificates: 2.1 Instrument Design										
Declaration of compliance with the order 2.1 acc. EN 10204 for instrument design						C6				
Calibration Record										
Calibration record								CB		
Separate calibration record								CC		
Certificates: SIL2										
SIL2 - Declaration of Conformity									CL	
Certificates: MVO Approval										
MVO approval									(Note: 12)	CR
Certificates: GOST										
GOST Russia - Without Explosion Protection										WC
GOST Kazakhstan - Without Explosion Protection										WD
GOST Ukraine - Without Explosion Protection										WE
GOST Belarus - Without Explosion Protection										WF

Additional ordering information for model 261GS		XX	XX	XX	XX
Material: 2.1 Compliance					
Certificate of compliance with the order 2.1 acc. EN 10204 for process wetted parts		H1			
Material: 3.1 Inspection					
Inspection certificate 3.1 acc. EN 10204 of process wetted parts		(Note: 13)	H3		
Material: 2.2 Test Report					
Test report 2.2 acc. EN 10204 of the pressure bearing and process wetted parts				H4	
Connector Type					
Miniature connector M12 x 1 (without mating plug)					U2
Harting Han 8D (8U) - Straight entry		(Note: 14)			U3

- Note 1: Suitable for oxygen applications
Note 2: Only with Sensor code C, F with diaphragm made of ceramic
Note 3: Not available with Sensor code C, F
Note 4: Suitable for oxygen applications / Only with Sensor code C, F with diaphragm made of ceramic
Note 5: With Cable Gland made of Plastic
Note 6: Select connector with additional ordering code
Note 7: Without cable gland
Note 8: Additional options to be ordered by additional ordering code
Note 9: Additional options not requested / Not available for electrical connection with connector
Note 10: Not available with electrical connection with connector
Note 11: Only available with inert fill and with sensor code C, F with diaphragm made of ceramic - Viton gasket
Note 12: Only with Fill Fluid White oil
Note 13: Minor parts with factory certificate acc. EN 10204
Note 14: Only for electrical connection with Harting Han connector

Standard delivery scope (changes possible with additional ordering code)

- For general-purpose applications (no Ex applications)
- Buna O-ring for G 1/2 process connection, flush diaphragm
- No display, no mounting bracket
- English-language operating instructions; English and German-language labels
- Configuration with kPa and °C units
- No test, inspection, or material certificates

Unless otherwise specified prior to manufacture, the customer shall be responsible for the selection of suitable parts that make contact with the medium and appropriate filling fluids in order to ensure compatibility with the relevant process medium.

Model 261GS for gauge pressure

Model 261AS for absolute pressure

Basic ordering information 261AS Absolute Pressure Transmitters

Select one character or set of characters from each category and specify complete catalog number.

Refer to additional ordering information and specify one or more codes for each transmitter if additional options are required.

Base model – 1 st to 5 th characters				261AS	X	X	X	X	X	X
Absolute pressure transmitter, compact class, base accuracy 0.1 %										
Sensor - Span Limits – 6th characters										continued see next page
6 kPa	60 mbar	24 in. H ₂ O (45 mm Hg)			C					
40 kPa	400 mbar	160 in. H ₂ O (300 mm Hg)			F					
250 kPa	2500 mbar	1000 in. H ₂ O (1875 mm Hg)			L					
1000 kPa	10 bar	145 psi			D					
3000 kPa	30 bar	435 psi			U					
10000 kPa	100 bar	1450 psi			R					
Diaphragm Material / Fill Fluid – 7th characters										
Hastelloy C-276		Silicone oil	NACE							K
Hastelloy C-276 gold-plated		Silicone oil	NACE							G
AISI 316L SST (1.4435)		Silicone oil	NACE							S
Hastelloy C-276		Inert Fluid	NACE	(Note 1)						F
Hastelloy C-276 gold-plated		Inert Fluid	NACE	(Note 1)						E
AISI 316L SST (1.4435)		Inert Fluid	NACE	(Note 1)						A
Hastelloy C-276		White oil (FDA)	NACE							Z
AISI 316L SST (1.4435))		White oil (FDA)	NACE							N
Ceramic		No filling	NACE	(Note 2)						J
Process Connection Material / Process Connection – 8th characters										
AISI 316L SST (1.4404)		1/2-14 NPT female	NACE							B
AISI 316L SST (1.4404)		DIN EN 837-1 G 1/2 B	NACE							P
AISI 316L SST (1.4404)		G 1/2 in. front bonded diaphragm	NACE	(Note 3)						S
AISI 316L SST (1.4404)		1/2-14 NPT male	NACE							T
AISI 316L SST (1.4404)		DIN EN 837-1 G 1/2 B (HP)	NACE	(Note 3)						U
AISI 316L SST (1.4404)		For ball valve connection	NACE	(Note 3)						V
AISI 316L SST (1.4404)		DIN 16288 M20 x 1,5	NACE							L

Basic ordering information model 261GS Absolute Pressure Transmitter		X	X	X
Gasket – 9th characters				
Viton, NACE	(Note: 4)	5		
Perfluorelastomere, NACE (max. 0.6 MPa)	(Note: 2)	6		
Perbunan	(Note: 2)	8		
None,, NACE		N		
Electronic Housing Material / Electrical Connection – 10th characters				
AISI 316L SST (1.4404) / M16 x 1.5 (with cable gland made of plastic)	(Note: 5)		2	
AISI 316L SST (1.4404) / 1/2-14 NPT (without cable gland)	(Note: 7)		S	
AISI 316L SST (1.4404) / M20 x 1.5 (with cable gland made of plastic)	(Note: 5)		T	
AISI 316L SST (1.4404) / Harting Han Connector	(Note: 6)		3	
AISI 316L SST (1.4404) / Miniature Connector	(Note: 6)		Z	
Output – 11th characters				
HART digital communication and 4 ... 20 mA (Additional options not requested)	(Note: 9)			H
HART digital communication and 4 ... 20 mA (Additional options to be ordered by additional ordering code)	(Note: 8)			1

Model 261GS for gauge pressure

Model 261AS for absolute pressure

Additional ordering information for model 261AS

Add one or more 2-digit code(s) after the basic ordering information to select all required options.

	XX	XX	XX	XX	XX	XX	XX
Explosion Protection Certification							
Factory Mutual (FM) - Intrinsically Safe (Note:10)	EA						
Canadian Standard Association (CSA) - Intrinsically Safe (Note:10)	ED						
ATEX Group II Category 1/2 G - Intrinsic Safety EEx ia	EH						
ATEX Group II Category 1/2 G and 1/2 D - Intrinsic Safety EEx ia (without Cable Gland) (Note:10)	EL						
IECEX Ex ia IIC T6 + Ex nA IIC T6, Gas	ER						
IECEX Ex ia IIC T6 + Ex nA IIC T6 + Ex tb, Gas & Dust	ES						
GOST Russia - EEx ia	W1						
GOST Kazakhstan - EEx ia	W3						
GOST Ukraine - EEx ia	WA						
GOST Belarus - EEx ia	WG						
NEPSI Ex ia IIC T - T6 Gas	X3						
NEPSI Ex ia IIC T - T6 Gas & Dust	X4						
Integrated Digital Display (LCD)							
With integrated LCD display		L1					
Electronic Housing: Ground Terminal							
Housing with external grounding terminal			AA				
Electronic Housing: Cable Gland							
Cable Gland M16 x 1.5 / M20 x 1.5 and atmosphere ventilation of metal				AB			
Mounting Bracket Shape / Material							
For pipe mounting / AISI 304 SST (1.4301)					B2		
For wall mounting / AISI 304 SST (1.4301)					B4		
Applications: Oxygen							
Oil- and grease-free, for oxygen applications (O2)							
(Pmax = 21 MPa / 210 bar / 3045 psi, Tmax = 60 °C / 140 °F) (Note:11)						P1	
Operating Instruction Language							
German							M1
Italian							M2
Spanish							M3
French							M4
English							M5
Swedish							M7
Finnish							M8
Russian							MB
Dutch							MD

Additional ordering information for model 261AS	XX	XX	XX	XX	XX	XX	XX	XX	XX	XX
Additional Tag Plate										
Stainless steel	I1									
Certificates: 3.1 Calibration										
Inspection certificate 3.1 acc. EN 10204 of calibration		C1								
Certificates: 3.1 Cleanliness Stage										
Inspection certificate 3.1 acc. EN 10204 of cleanliness stage			C3							
Certificates: 3.1 Helium Leakage Test										
Inspection certificate 3.1 acc. EN 10204 of helium leakage test of the sensor module				C4						
Certificates: 3.1 Pressure Test										
Inspection certificate 3.1 acc. EN 10204 of pressure test					C5					
Certificates: 2.1 Instrument Design										
Declaration of compliance with the order 2.1 acc. EN 10204 for instrument design						C6				
Certificates: SIL2										
SIL2 - Declaration of Conformity								CL		
Certificates: MVO Approval										
MVO approval	(Note: 12)								CR	
Calibration Record										
Calibration record										CB
Separate calibration record										CC
Certificates: GOST										
GOST Russia - Without Explosion Protection										WC
GOST Kazakhstan - Without Explosion Protection										WD
GOST Ukraine - Without Explosion Protection										WE
GOST Belarus - Without Explosion Protection										WF

Model 261GS for gauge pressure

Model 261AS for absolute pressure

Additional ordering information for model 261AS		XX	XX	XX	XX
Material: 2.1 Compliance					
Certificate of compliance with the order 2.1 acc. EN 10204 for process wetted parts		H1			
Material: 3.1 Inspection					
Inspection certificate 3.1 acc. EN 10204 of process wetted parts (Note: 13)			H3		
Material: 2.2 Test Report					
Test report 2.2 acc. EN 10204 of the pressure bearing and process wetted parts				H4	
Connector Type					
Miniature connector M12 x 1 (without mating plug)					U2
Harting Han 8D (8U) - Straight entry (Note: 14)					U3

- Note 1: Suitable for oxygen applications
- Note 2: Only with Sensor code C, F with diaphragm made of ceramic
- Note 3: Not available with Sensor code C, F
- Note 4: Suitable for oxygen applications / Only with Sensor code C, F with diaphragm made of ceramic
- Note 5: With Cable Gland made of Plastic
- Note 6: Select connector with additional ordering code
- Note 7: Without cable gland
- Note 8: Additional options to be ordered by additional ordering code
- Note 9: Additional options not requested / Not available for electrical connection with connector
- Note 10: Not available with electrical connection with connector
- Note 11: Only available with inert fill and with sensor code C, F with diaphragm made of ceramic - Viton gasket
- Note 12: Only with Fill Fluid White oil
- Note 13: Minor parts with factory certificate acc. EN 10204
- Note 14: Only for electrical connection with Harting Han connector

Standard delivery scope (changes possible with additional ordering code)

- For general-purpose applications (no Ex applications)
- Buna O-ring for G 1/2 process connection, flush diaphragm
- No display, no mounting bracket
- English-language operating instructions; English and German-language labels
- Configuration with kPa and °C units
- No test, inspection, or material certificates

Unless otherwise specified prior to manufacture, the customer shall be responsible for the selection of suitable parts that make contact with the medium and appropriate filling fluids in order to ensure compatibility with the relevant process medium.

Contact us

ABB Ltd.

Process Automation

Howard Road, St. Neots
Cambridgeshire, PE19 8EU
UK

Tel: +44 (0)1480 475321

Fax: +44 (0)1480 217948

ABB Inc.

Process Automation

125 E. County Line Road
Warminster PA 18974
USA

Tel: +1 215 674 6000

Fax: +1 215 674 7183

ABB Automation Products GmbH

Process Automation

Schillerstr. 72
32425 Minden
Germany

Tel: +49 551 905-534

Fax: +49 551 905-555

www.abb.com

Note

We reserve the right to make technical changes and changes affecting content to this document at any time without prior notice.

Orders are subject to the agreed detailed terms and conditions. ABB cannot be held responsible for any errors or omissions in this document.

We reserve all rights to this document and its content, including images. This document must not be copied, shared with third parties, or its content (in whole or in part) used without the prior written permission of ABB.

Copyright© 2011 ABB

All rights reserved

3KXP200005R1001

™ Hastelloy C276 is a Cabot Corporation trademark

™ Viton is a DuPont de Nemours trademark

SS/261GS/AS-EN Rev. 06.08.2011